

Series 3200 Explosion-Proof Smart Pressure Transmitter

Specifications - Installation and Operating Instructions



Table of Contents

Chapter 1. Introduction

- 1.1 Using This Manual
- 1.2 Overview of Transmitter
- 1.3 Software Compatibility
- 1.4 Transmitter Components

Chapter 2. Handling Cautions

- 2.1 Unpacking Transmitters and Specifications Check
- 2.2 Models and Specifications Check
- 2.3 Storage
- 2.4 Selecting the Installation Locations
- 2.5 Calibration after Installation
- 2.6 Pressure Connections
- 2.7 Waterproofing Cable Conduit Connections
- 2.8 Restrictions on Use of Radio Transceiver
- 2.9 Installation Resistance Test and Dielectric Strength Test
- 2.10 EMC Conformity Standards

Chapter 3. Transmitter Functions

- 3.1 Overview
- 3.2 Safety Messages
- 3.3 Warning
- 3.4 Fail Mode Alarm
- 3.5 EEPROM-Write Enable and Disable Mode Jumper
- 3.6 Configuration of Alarm and Security Jumper Procedures
- 3.7 Configuration of Zero and Span Procedure
- 3.8 Commissioning on the Bench with HHT

Chapter 4. Installation

- 4.1 Overview
- 4.2 Safety Messages
- 4.3 Warning
- 4.4 Commissioning on the Bench with Hand-Held Terminal
- 4.5 General Considerations
- 4.6 Electrical Considerations
- 4.7 Wiring
- 4.8 Mechanical Considerations
- 4.9 Environmental Considerations

Chapter 5. On-line Operation

- 5.1 Overview
- 5.2 Safety Messages
- 5.3 Configuration Data Review
- 5.4 Check Output
- 5.5 Basic Setup
- 5.6 Detail Setup
- 5.7 Information Variables Setup
- 5.8 Diagnostics and Services
- 5.9 Calibration

Chapter 6. Maintenance

- 6.1 Overview
- 6.2 Safety Messages
- 6.3 Hardware Diagnosis
- 6.4 Hardware Maintenance

Appendix I

3200 Smart Pressure Transmitter LCD Display Code

Chapter 1 Introduction

The 3200 Smart Pressure Transmitter is calibrated at the factory before shipping. To ensure correct and efficient use of the instrument, please read the manual thoroughly and fully understand how to operate the instrument before operation.

1. The contents of this manual are subject to change without prior notice.
2. All rights reserved. No part of this manual may be reproduced in any form without Dwyer Instruments, LLC written permission.
3. If any question arises, errors are found or if any information is missing from this manual, please inform Dwyer Instruments, LLC
4. The specifications covered by this manual are limited to standard transmitters and do not cover custom-made instrument.
5. Please note that changes in the specifications, construction, or component parts of the instrument may not immediately be reflected in this manual at the time of change, provided that postponement of revisions will not cause difficulty to the user from a functional or performance standpoint.

1.1 Using This Manual

The operating manual provides information on installing, operating, and maintaining the Mercoid® Model 3200 Smart Pressure Transmitter. The Chapters are organized as follows.

Chapter 2 Handling Cautions

Chapter 2 provides instructions on commissioning and operating Model 3200 Smart Pressure Transmitters. Informations on software functions, configuration parameters, and on-line variables are also included.

Chapter 3 Transmitter Functions

Chapter 3 contains suggestions on handling the Model 3200 Smart Pressure Transmitters.

Chapter 4 Installation

Chapter 4 contains mechanical, environment consideration and electrical installation instructions for the Model 3200 Smart Pressure Transmitters.

Chapter 5 On-line Operation

Chapter 5 describes how to configure the parameters of the Model 3200 Smart Pressure Transmitter. See the following list for the details.

1. Regulations of circuit's Input/Output characteristics; Sensor or Output Trim
2. Changing the output characteristic; Range Configuration, Output Type, Dampening, Unit
3. Changing the general data; Tag No., Date, Message, etc.

Chapter 6 Maintenance

Chapter 6 contains hardware diagnostics, troubleshooting and maintenance task.

1.2 Overview of Transmitter

The Mercoid® Smart Pressure Transmitter is a microprocessor based pressure transmitter with a capacitance sensor optimized for draft measurement. The Model 3200 has a true draft analog range from 0 to 20 mA. This transmitter is explosion-proof, high precision accuracy, reliability and has digital communication for remote communication system.

The Model 3200 is enabled with HART® communication with Host, HHT (HART® Communicator) or PC Configurator. The transmitter's various variables in host are able to be changed, configured and calibrated by users. The HART® Communication between DC power supply and transmitter requires a 250~ 550 Ω resistance.

1.3 Software Compatibility

The Mercoid® Smart Pressure Transmitter's software is implemented at the factory. The following functions can be configured using a HHT (HART® Communicator).

Function	Function Supports		
	ZERO/SPAN Button Rev.58	PC/PDA	HART HHT
ZERO/SPAN	•	•	•
ZERO TRIM	•	•	•
ZERO Adj	•	•	•
Units set	•	•	•
Range set	•	•	•
Dampening set	•	•	•
LCD Decimal set	•	•	Δ
• : Supported			
Δ : Supported but update required			

Chapter 2 Handling Cautions

This chapter consists of cautions for transmitter handling, storage, installation, insulation and explosion structure, etc.

Step	Job	Job Details	Instrument
1	Unpacking Model and Specifications Storage	• Unpack transmitter packing	<ul style="list-style-type: none"> • HHT • Pressure Source • Galvanometer (Engineering)
2		• Make sure the transmitter nameplate matches the model number on the PO	
3		• In a dry, non-vibration and non-impact area	
4	Calibration	• Ambient temperature around 77°F (25°C) and 65% relative humidity	
5		• Configuration of the Range, Zero/ Span, Unit, Tag, Dampening Time, Transfer Function, DA Trim and other parameters	
6	Installation Locations	• Where ambient temperature are consistant	
7		• Exposure to chemical corrosion, etc.	
8	Mechanical Considerations	• Where shock and vibration are minimal	
9		• Where the area classification does not exceed the exponion-proof rating	
10	Electrical Considerations	• Where maintenance is easy	
11		• Where transmitter can be handled easily	
12	Mounting and Installation	• Be cautious of process connections leaking	
13		• 24 VDC (Power Supply is 11.9 VDC – 45 VDC)	
14	Calibration on Spot	• For HART® communication, total resistance on transmitter terminal loop should between 250 – 550 Ω	
15		• When mounting the transmitter, an appropriate bracket should be used	
16	Operation	• The transmitter should be mounted securely to prevent swing	
17		• Sensor Zero Trim should be done after ten seconds after the differential pressure stabilizes	
18	Operation	• Make sure that PV value is zero and current is 4 mA	
19		• Make sure the transmitter operates properly	

2.1 Unpacking

When moving the transmitter to the installation site, keep it in the original packaging. Unpack the transmitter at the installation site to avoid damage on the way.

2.2 Models and Specifications Check

The model number and specifications are indicated on the nameplate. Please check the specification and model number.

2.3 Storage

The following precautions must be observed when storing the instrument, especially for a long period.

1. Select a storage area that meets the following conditions:
 - is not exposed to rain or water.
 - minimal vibration and shock.
 - stored at normal temperature and humidity (approx. 77°F (25°C), 65% RH).

The ambient temperature and relative humidity ratings are:

Ambient Temperature: -40 to 185°F (-40 to 85°C)
 (without LCD module)
 -22 to 176°F (-30 to 80°C)
 (with LCD module)

General Use: -4 to 140°F (-20 to 60°C)
 Relative Humidity: 5% ~ 98% RH at 104°F (40°C)

2. When storing the transmitter, repack it the way it was delivered from the factory.
3. If storing a used transmitter, thoroughly clean the diaphragm surfaces, so that no media remains. Make sure the transmitter assemblies are securely mounted before storing.

2.4 Selecting Installation Locations

The transmitter is designed to withstand severe environmental conditions. However, to ensure stable and accurate operation, the following precautions must be observed when selecting an installation location.

1. Ambient Temperature
Avoid locations subject to wide temperature variations or a significant temperature gradient. If the location is exposed to radiant heat from plant equipment, provide adequate insulation or ventilation.
2. Ambient Atmosphere
Avoid installing the transmitter in a corrosive atmosphere. If the transmitter must be installed in a corrosive atmosphere, there must be adequate ventilation. Precautions must be put into place to prevent intrusion or stagnation of rainwater in conduits.
3. Shock and Vibration
Select an installation site with minimal shock and vibration (although the transmitter is designed to be relatively resistant to shock and vibration).
4. Installation of Explosion-Proof Transmitters
Explosion-Proof transmitters can be installed in hazardous areas according to the gas types for which they are certified.
5. Select a place where transmitter can be maintained easily.

2.5 Calibration on Spot after Installation

1. Sensor Zero Trim should be done after transmitter is installed, because the zero point is not configured for mounting status.
2. When calibrating the Sensor Zero Trim apply a pressure of zero in advance, Sensor Zero Trim the sensor when the pressure is sufficiently stabilized (after approximately 10 seconds).
3. Sensor Zero Trimming can also be done with the Zero/Span button or a HHT (HART® Communicator), PC or PDA configurator.
4. Refer to On-line Operation for configuring other parameters.

2.6 Pressure Connections

WARNING Instrument installed in the process under pressure.

- Never loosen or tighten as it may cause dangerous spouting of process fluid. If the process fluid is toxic or otherwise harmful, take appropriate care to avoid contact or inhalation of vapors even after disconnecting the instrument from process line for maintenance.

The following precautions must be observed in order to safely operate the transmitter under pressure.

1. Never apply a pressure higher than the specified maximum working pressure.
2. Confirm the option pressure of transmitter. It is necessary to use standardized and quality-approved parts.
3. There should be isolation valves in case of leakage.

2.7 Waterproofing Cable Conduit Connections

Apply a non-hardening sealant (silicone or tape, etc.) to the threads to waterproof the transmitter cable conduit connections.

2.8 Restrictions on Use of Radio Transceivers

WARNING Although the transmitter has been designed to resist high frequency electrical noise, if a radio transceiver is used near the transmitter's external wiring, the transmitter may be affected by high frequency noise pickup. To test for such effects, bring the transceiver in slowly from a distance of several feet from the transmitter, and observe the measurement loop for noise affects. Always use the transceiver outside the area affected by noise.

2.9 Insulation Resistance Test and Dielectric Strength Test

Since the transmitter has undergone insulation resistance and dielectric strength tests at the factory, normally these tests are not required. However, if required, observe the following precautions in the test procedures.

1. Do not perform such tests more frequently than necessary. Even test voltages, that do not cause visible damage to the insulation, may degrade the insulation and reduce safety margins.
2. Never apply a voltage exceeding 500 VDC for the insulation resistance test, or a voltage exceeding 500VAC for the dielectric strength test.
3. Before conducting these tests, disconnect all signal lines from the transmitter terminals. Perform the tests using the following procedure.

Insulation Resistance Test

1. Short-circuit the + and - SUPPLY terminals in the terminal box.
2. Turn OFF the insulation tester. Then connect the insulation tester plus (+) lead wire to the shorted SUPPLY terminals and the minus (-) lead wire to the grounding terminal.
3. Turn ON the insulation tester power and measure the insulation resistance. The voltage should be applied briefly to verify that insulation resistance is at least 20MΩ.

4. After completing the test and being very careful not to touch exposed conductors. Disconnect the insulation tester and connect a 100kW resistor between the grounding terminal and the short-circuiting SUPPLY terminals. Leave this resistor connected at least three seconds to discharge any static potential. Do not touch the terminal while it is discharging.

Dielectric Strength Test

1. Short-circuit the + and - SUPPLY terminals in the terminal box.
2. Turn off the dielectric strength tester. Then connect the tester between the shorted SUPPLY terminal and the grounding terminal. Be sure to connect the grounding lead of the dielectric strength tester to the ground terminal.
3. Set the current limit on the dielectric strength tester to 10mA, then turn on the power and gradually increase the tester voltage from '0' to the specified voltage.
4. When the specified voltage is reached, hold it for one minute.
5. After completing this test, slowly decrease the voltage to avoid any voltage surges.

2.10 Explosion-Proof Rating

2-10-1. FM Certification

HAZARDOUS LOCATION ELECTRICAL EQUIPMENT

Equipment Rating: Explosion-Proof for use in Class I, Division 1, Groups A, B, C and D;

Dust-Ignition-Proof for Class II/III, Division 1, Groups E, F and G;

Nonincensive for use in Class I, Division 2, Groups A, B, C and D;

Suitable for use in Class II, Division 2, Groups E, F and G; and

Suitable for Class III, Division 1;

Hazardous(classified) location, indoor and outdoor (NEMA Type 4X/IP67).

NOTICE Electrical Data

1. Supply Voltage: 42 VDC max
2. Output Signal: 4-20 mA + HART

NOTICE Electrical Connection: 1/2"-14 NPT Female

NOTICE Installation

1. All wiring shall comply with local installation requirement.
2. The cable glands and blanking elements shall be of a certified flameproof type, suitable for the condition of use and correctly installed. Also those devices should be endured at the 130°C.
3. Housing Ground must be followed to "local electrical codes". The most efficient ground procedure is to connect directly to the earth as least impedance.
 1. How to Housing Ground:
 - A. Internal Ground Connection:
Internal ground connection screw is located in terminal in housing; the screw can be identified as ground sign.
 - B. External Ground Assembly:
This is located in the right side of housing and identified as ground sign. (Grounding with a cable lug)
2. When use tubing, stopping boxes must be connected with the wall of housing directly.
3. Tubing is installed a minimum of 5 threads.
4. Sensor is to be threaded a minimum of 7 threads and prevented from turing by tightening the housing rotation set screw.
5. Do not disassemble flameproof Joints but in an unavoidable case to disassemble it or need the specification of flameproof Joints, contact the manufacturer before doing.

NOTICE Operation

WARNING DO NOT OPEN WHEN AN EXPLOSIVE ATMOSPHERE MAY BE PRESENT.

1. Take care not to generate mechanical spark when access to the instrument and peripheral devices in hazardous location.

NOTICE Maintenance and Repair

The instrument modification or parts replacement by other than authorized representative of Dwyer/Mercoid is prohibited and will void explosion-proof/flame-proof.

2.11 EMC Conformity Standards

EMI (Emission): EN55011

EMS (Immunity): EN50082-2

Dwyer Instruments, LLC recommends customer use metal conduit wiring or twisted pair shield cable for signal wiring to conform with EMC regulation, when installing the Mercoid® 3200 transmitters.

Chapter 3 Transmitter Functions

3.1 Overview

This chapter contains information on operating the Model 3200. Tasks that should be performed on the bench prior to installation are explained NOTICE in this chapter.

3.2 Safety Message

Procedures and instructions in this chapter may require special precautions to ensure the safety of the personnel performing the operations. Potential safety issues are indicated by a warning symbol (▲). Refer to the following safety messages before performing an operation preceded by this symbol.

3.3 Warning

▲ WARNING Explosion can result in death or serious injury:

- Do not remove the transmitter covers in explosion environments when the circuit is powered.
- Transmitter covers must be fully engaged to meet explosion-proof requirements.

▲ WARNING Electrical shock can result in death or serious injury:

- Only qualified personnel can install the transmitter.

3.4 Fail Mode Alarm

Mercoid® Smart Pressure Transmitter automatically and continuously performs self-diagnostic test. If the self-diagnostic test detects a failure, the transmitter drives the output outside of the normal operation values. The transmitter will drive its output low (down) or high (up) based on the position of the failure mode alarm jumper. See **Table 3.1** for output values.

Level	4~20mA Saturation	4~20mA Alarm
Low/Down	3.9 mA	≤ 3.75 mA
High/Up	20.8 mA	≥ 21.75 mA

Table 3.1 Standard alarm and saturation values

▲ WARNING Electrical shock can result in serious injury:

- Avoid contact with the leads and terminals. High voltage, that may be present, on leads can cause electrical shock.

Fail Safe mode can be set via Jumper switches provided on the LCD module or the main CPU module. The jumper switch for an indicating transmitter, located on the LCD module, can be set to the right (fail down i.e. ≤ 3.75 mA) or left (fail up i.e. ≥ 21.75 mA). For nonindicating transmitters the jumper switch is located on the main CPU module, it can be set up (fail up to ≥ 21.75 mA) or down (fail down to ≤ 3.75 mA). Refer to Figure 3-1 for detailed summary of jumper settings for both CPU and LCD modules.

Fail Safe Mode Selection (LCD & CPU Module)			
Select Fail Mode	Both LCD Module and CPU Module		Only CPU Module
	CPU Module	LCD Module	LCD Module
Fail Down	Down	D	D
Fail Up	Down	U	U
	Up	U or D	U

1. WR_EN (EEPROM Write Enable)

DOWN: ENABLE

UP: DISABLE

2. Fail Mode (Alarm)

DOWN: LOW

UP: HIGH

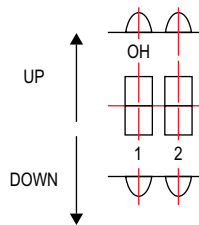

Fail Mode for LCD Module Selection Jumper Switch									
U	O	O	O			O	O	O	D
(If Down)				FAIL MODE		(If Up)			

Figure 3-1: Fail mode and EEPROM-write selection jumper switch

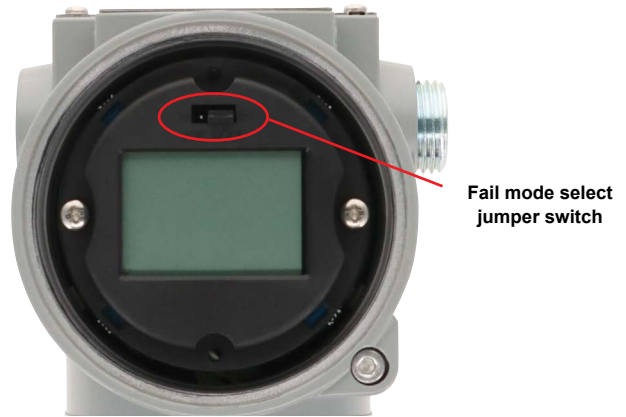

Figure 3-2: Fail mode selection jumper switch for LCD module

3-5 EEPROM-Write Enable / Disable Mode Switch

EEPROM (Electrically Erasable Programmable ROM), included on the CPU module, is used by the transmitter to save/restore configuration variables. To protect the transmitter from any unauthorized changes, a hardware lockout feature can be implemented by using the Write-Protect mode jumper switch provided on the main CPU Module. This Jumper switch is designated as "EEP-Write DIS/EN" on the CPU Module. If the jumper switch is connected to DIS, this disables writing/changing of any data saved in the EEPROM. On the other hand, if the jumper switch is set to "EN", changes can be made to the configuration data stored in the EEPROM. The factory default setting is "EN" (Enable) for all transmitters. The location of the Wire Protect Jumper Switch can be seen in **Figure 3-3**.

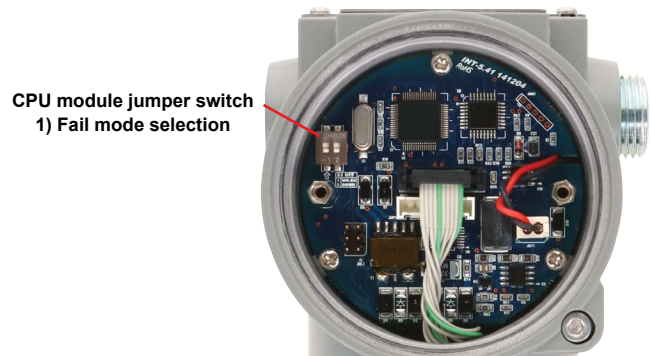

Figure 3-3: CPU module fail mode, EEPROM-write selection jumper switch

The 3200 has two security settings.

1. Security Jumper: the transmitter configuration parameters are protected.
2. Physically removing Zero and Span Magnetic Buttons: you are unable to regulate zero and span locally.

3.5.1 Security Jumper (EEPROM Write Protect)

Prevents the transmitter's configured parameters from being changed.

3.5.2 Zero and Span Buttons

By removing the Magnetic Buttons, you can't configure the transmitter using the Zero and Span locally.

3.6 Configuration of Alarm and Security Jumper Procedures

Changing jumper position.

1. If the transmitter is installed, cutoff power.
2. Open the front cover. If the transmitter is powered, don't open the cover.
3. Move the jumper to the preferred position.
4. Close the front housing cover. You must fully engage the cover to meet explosion-proof requirements.

3.7 Configuration of Zero and Span Procedures

The ZERO and SPAN buttons are under the transmitter's nameplate. The ZERO, SPAN, ZERO TRIM, ZERO ADJ, Units, Range, Dampening, LCD and decimal set functions are configurable using the ZERO / SPAN buttons.

Zero/Span Configuration Process

Remove both name plate screws on the upper part of transmitter. Remove top name plate to access the Zero and Span Buttons. (following **Figure 3-4**)

1. Zero Configurations

Set the current process value for Lower Range Value (4 mA). Apply zero differential pressure for 10 seconds and push the Zero Button for 5 seconds. The LCD should display "Zero". Push the Zero button for 3 seconds, after 1 second the LCD should display "-ZE-". This message means the zero configuration is finished. If the zero configuration failed, the LCD will display "SPER" or "SEtE", try repeating the zero configuration steps.

2. Span Configurations

Apply the desired pressure for 10 seconds and push the Span Button for 5 seconds. The LCD should display "Span". Push the Span button for 3 seconds, after 1 second the LCD should display "-SP-". This message means that the span configuration is finished. If the span configuration failed the LCD will display "SPER" or "SEtE", try repeating the span configuration steps.

• Please refer to Appendix 1 for the button error and LCD display message.

The other functions supported by the ZERO / SPAN Buttons are below.

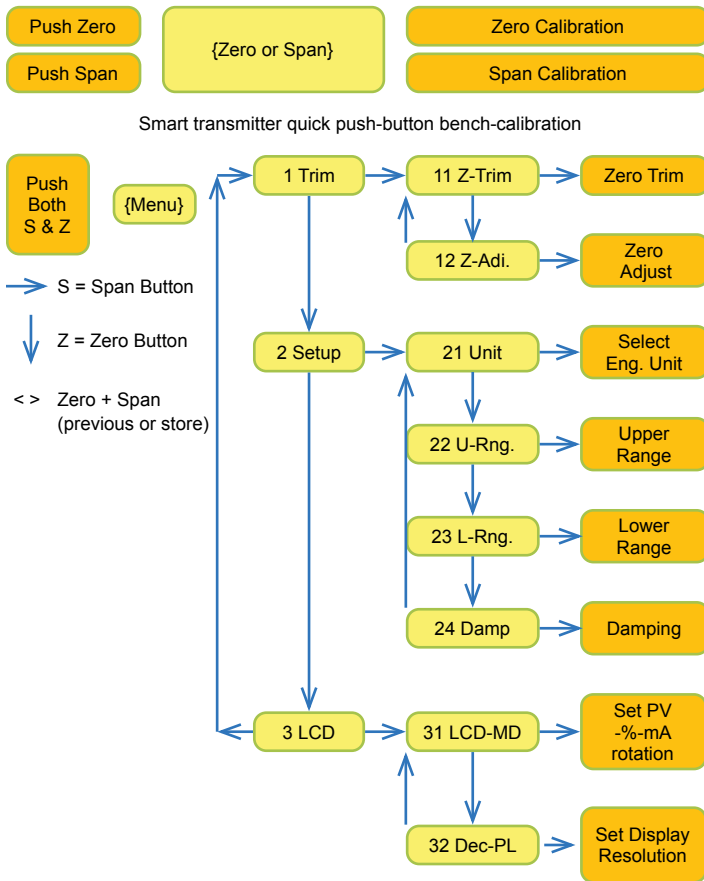

Menu tree for zero+span button function

1. Moving between menus: Zero

2. Enter or moving to sub menu: Span

3. Moving to top menu: Zero+Span

- Press the button for 3 seconds to execute each function. After 3 seconds press the Zero+Span buttons, the LCD display will change from Menu to Trim. To see the next menu, press the Zero button for 3 seconds. Use the Zero button to move down the directory.
- Use the Span button to select the displayed menu. The same procedure will be used for the sub menus.

4. How to select a numerical value

- Functions use numerical values: 12 Zero Adjustment, 22 Change Upper Range Value, 23 Change Lower Range Value, 24 Dampening Second
- How to select numerical value: First, select an increasing rate (10n), then change each decimal value to increase or decrease as wanted. For example, select 3810: Select increasing rate 1000 -> Increase 3 times -> Select increasing rate 100 -> Increase 8 times -> Select increasing rate as 10 -> Increase 1 time
- To select the increase / decrease steps : SelInc message will be displayed on the bottom of the LCD. Select parameter and press the Zero button : The decimal value will be changed when the Zero button is pressed. After set, press the span button to execute the parameter.
- To set the required values using the Zero/Span buttons: VALUE message will be displayed on the bottom of the LCD.
 1. Press the Zero button, the menu will increase 1 item.
 2. Press the Span button, the menu will decrease 1 item.
 3. After setting, save the parameter by pressing the Zero+Span buttons.
- To set the final value, repeat 3 and 4.
- After setting the final parameter, exit the menu by pressing the Zero+Span buttons.

5. Exercises for each function

- ZERO TRIM
 1. Access the menu by pressing the Zero+Span buttons.
 2. Move to the sub directory using the Span button until the 1 TRIM message appears on the display.
 3. Change the Zero Trim Function by using the Span button until the 11 Z-TRIM message appears on the display.
- ZERO ADJUSTMENT : Change the PV value to 14
 1. Exit the menu by pressing the Zero+Span button.
 2. Moving thru the sub directory using the Span button until 1 TRIM message appears.
 3. Moving thru the sub directory using the Zero button until 11 Z-TRIM message appears.
 4. Access the Zero Adjustment function by pressing the Span button until the 12 Z-ADJ messages appears.
 5. When the SelInc message appears, press the Zero button repetitively until the 10.0 message appears on the LCD. Set the value by pressing the Span button.
 6. When the VALUE message appears, change the LCD value to 10.0 and press the Zero button, then press the Zero+Span buttons.
 7. When SelInc message appears, change the LCD value to 1.0 and press the Zero button, then set the value and press the Span button. Press the Zero+Span buttons after the LCD value changes to 14.0.
 8. To save the settings, press the Zero+Span buttons until the SelInc message appears.
- CHANGE UNITS
 1. Access the menu by pressing the Zero+Span buttons.
 2. Moving to next menu by pressing the Zero button until the 1 TRIM message appears.
 3. Moving thru the sub directory press the Span button until the 2 SETUP message appears.
 4. Press the Span button to access 21 UNIT, press Span again to access Change Unit.
 5. Save the values by pressing the Span button when the desired value is displayed on the LCD.
- CHANGE UPPER RANGE VALUE
 1. Access the menu by pressing the Zero+Span buttons.
 2. Move to the next menu by pressing the Zero button until the 1 TRIM message appears.
 3. Press the Span button until the 2 SETUP message appears.
 4. Press the Span button until the 21 Unit message appears.
 5. Press the Zero button until the 22 U-RNG message appears.
 6. Press the Span button until the Zero Adjustment message appears.
- CHANGE LOWER RANGE VALUE
 1. Access the menu by pressing the Zero+Span buttons.
 2. Move to the next menu by pressing the Zero button until the 1 TRIM message appears.
 3. Press the Span button until the 2 SETUP message appears.
 4. Press the Span button until the 21 Unit message appears.
 5. Press the Zero button until the 23 U-RNG message appears.
 6. Press the Zero button until the 23 L-RNG message appears.
 7. Press the Span button until the Change Lower Range Value message appears.

CAUTION 30 seconds without any action, the button function menu will return to normal operation.

- CHANGE LCD MODE (Cyclic or Fixed Display)
 1. Enter programming menu by pushing both (ZERO+SPAN) button together for 5 seconds. Release buttons when LCD displays Menu and display will automatically change to "1 TRIM" confirming access into programming menu.
 2. Push (ZERO) button when "1 TRIM" message appears on LCD. Release button when display changes to "2 SETUP".
 3. Push (ZERO) button and release when display changes to "3 LCD".
 4. To move into sub directory push (Span) button after "3 LCD" message appears on display. Release button when 31 LCD-MD message is displayed.
 5. To enter this sub-menu, push (Span) button and release when display changes to 311. Bottom line of display will show current Mode setting e.g. NOR-RO, NOR-PV etc.
 6. Push (Zero) button to cycle through available mode options and select desired LCD rotation mode. Options are: NOR-RO (rotate all PV, %, mA), NOR-PV (fixed PV), NOR-% (fixed %), NOR-mA fixed, ENG-RO, ENG-PV, ENG-% or ENG-mA.
 7. Push (Span) to save changes and EXIT programming mode.
- Decimal Place
 1. Access the menu by pressing the Zero+Span buttons.
 2. Move to the next menu by pressing the Zero button until the 1 TRIM message appears
 3. Press the Span button until the 2 SETUP message appears.
 4. Press the Span button until the 3 LCD message appears.
 5. Press the Span button until the 31 DEC-PL message appears.
 6. Press the Span button until the Decimal Place message appears, the decimal place will appear on the second line of the LCD as follows.

Display	Explanation	Max. Value
AUTO	Target value will be displayed automatically	99999
5-0	No decimal place	99999
4-1	Display one decimal place	9999.9
3-2	Display two decimal places	999.99
2-3	Display three decimal places	99.999
1-4	Display four decimal places	9.9999

7. The first line on the LCD will display 0.0.
8. The Decimal Place can be changed by pressing the Zero button. Save the setting by pressing the Span button after the decimal place has been selected.
9. The set value will display the PV value and Engineering value.
10. The LCD will display LCD_OV and the saved Unit when the pressure is over or under a set value.

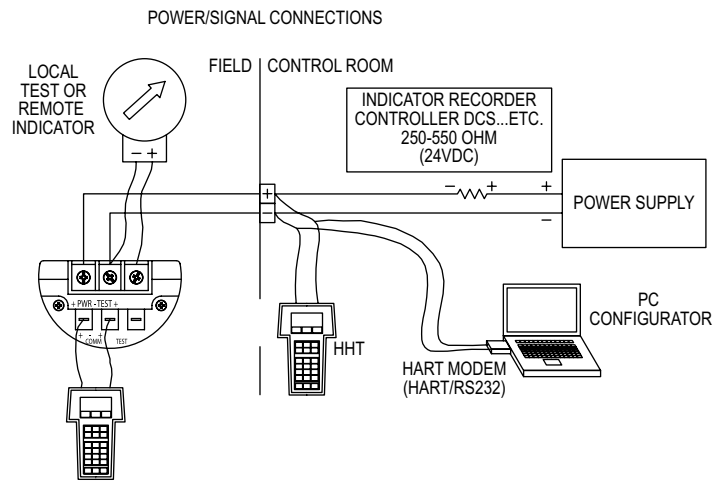

Figure 3-4: Transmitter zero/span configuration buttons

3.10 Shop Commissioning using HHT

The 3200 Pressure Transmitter can be commissioned using an HHT before or after installation.

▲ Connect an HHT (HART® HANDHELD Communicator) across the "COMM" pins for HART® communication. The TEST pin connections can be used for connecting a multimeter to measure the output current directly from the transmitter. Since the 3200 is a two wire loop powered transmitter, it requires an external loop power supply (11.9V to 45 VDC) to enable HART® communication. Any HART® communication via HHT (or PC based configurator) requires a minimum 250 ~ 550 (max) Ω loop resistance.



1. HHT (HART COMMUNICATOR) OR PC CONFIGURATOR MAY BE CONNECTED AT ANY TERMINAL POINT IN THE SIGNAL LOOP.
2. HART COMMUNICATION REQUIRES A LOOP RESISTANCE 250 AND 550 OHM (24VDC).
3. TRANSMITTER OPERATES ON 11.9 TO 45.0 VDC TERMINAL VOLTAGE. [APPLIED POWER]
 - *11.9 ~ 45.0 VDC FOR GENERAL OPERATION
 - *17.4 ~ 45.0 VDC FOR HART COMMUNICATION

Figure 3-5: Connecting the transmitter to HHT

Chapter 4 Installation

4.1 Overview

The information in Chapter 4 explains installation.

4.2 Safety Messages

Procedures and instructions in this chapter may require special safety measures to ensure the safety of the personnel performing the operation. Potential installation safety issues are indicated by a warning symbol (▲). Refer to the following safety messages before installing the 3200 pressure transmitter.

4.3 Warning

▲ **WARNING** Explosion can result in death or serious injury:

- Do not remove the transmitter covers in an explosion-proof environment when the circuit is powered.
- Both transmitter covers must be fully engaged to meet the explosion-proof requirements.

▲ **WARNING** Electrical shock can result in serious injury:

- Only qualified personnel can wire the pressure transmitter.

▲ **WARNING** Process leaks can cause death or serious injury:

- Install and tighten before applying pressure. If you don't, it can cause process leaks.

▲ **WARNING** Electrical shock can result in death or serious injury:

- Avoid contact with the leads and terminals.

4.4 Commissioning on the Bench with Hand-Held Terminal

The 3200 Pressure Transmitter can be commissioned before and after installation. Commissioning is easier if the transmitter is configured on a bench with an HHT before installation.

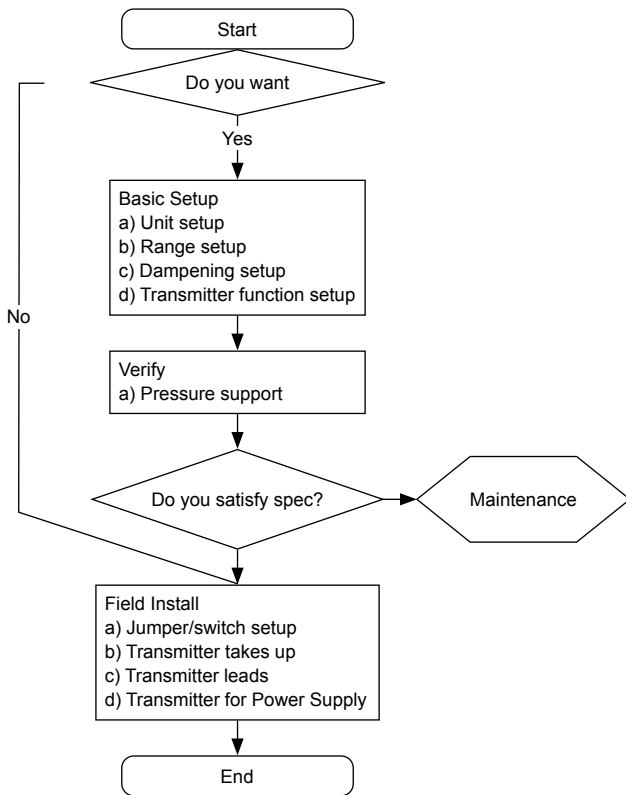

Figure 4-1: Installation flow chart

4.5 General Considerations

The transmitter can be mounted near the process to minimize piping. Keep in mind that easy access is required for personnel, field calibration, and installation. Install the transmitter in an area with minimal vibration, shock, and temperature fluctuations.

4.6 Electrical Considerations (Power Supply)

The transmitter housing is composed of two parts. One side is electronics, and the other side is terminal block. The terminal block side is the transmitter's front side and is labeled "Field Terminal" on the housing. The terminal block can be accessed by removing the front cover. When wiring the power supply to the transmitter make sure the positive and negative wires are connected correctly. A HHT configurator can be connected directly across the (COMM) pin terminal located just below the power supply (PWR) terminal block connections.

4.6.1 Power Supply

The 3200 Pressure Transmitter requires an 11.9 - 45 VDC power supply. A 250 ~ 550Ω (24 VDC) loop resistance is recommended for HART® communication. Loop resistance is the sum of the resistance in the loop.

$$\text{Max. Loop Resistance } [\Omega] = (E-11.9) \text{ [vdc]} / 0.022 \text{ [mA]}$$

4.7 Wiring

4.7.1 Wiring Caution

1. Install the signal cables away from potential sources of electrical noise such as transformers, electrical motors, etc.
2. Before wiring, remove electrical conduit cap.
3. All screwed connections on the housing must be sealed with waterproof sealant. We recommend use of silicone based sealants to minimize post-hardening.
4. Avoid running DC signal and AC power cables in the same ducts/cable conduits to avoid signal noise issues.
5. All explosion proof transmitters must meet the wiring & installation requirements specified within the applicable electrical codes.

4.7.2 Selecting the Wiring Materials

1. Use 600V shielded PVC wire or standard wire of the same class. (To ensure proper communication use 24 AWG or larger wire, and do not exceed 5000 feet.)
2. Use shielded wire in areas with electrical noise.
3. In areas with high or low ambient temperatures, use wire or cable that is rated for the extreme temperatures.
4. If the wire or cable is going to be used in oil, solvent, toxic gas or liquid, make sure it is rated accordingly.
5. Process wire or cable must not be soldered to the terminal lug. Spade connectors are recommended to connect the process wires to the transmitter.

4.7.3 Connecting External Wires to Transmitter

Terminal Box

1. Open the cover indicated "FIELD TERMINAL". Do not open the cover if the transmitter is located in an explosion-proof area and powered. Connect the power supply to the terminal indicated "+PWR" (left terminal) and "-" in the central terminal. Do not connect "+" power supply to "+" terminal "TEST". It will damage the test diode.
2. Seal and close the conduit connection to prevent humidity and explosion-proof atmosphere from entering the housing.
3. Transmitter power is supplied by signal wire. Do not install near high voltage wires or high voltage equipment.
4. Close the transmitter cover. To meet the explosion-proof ratings make sure the covers are fully engaged. **Note:** Do not power the transmitter with high voltage (AC). It can damage the transmitter.
5. You must connect a 250~550 Ω Resistor in Current Loop (between Power Supply and Transmitter) for HART® Communication. See **Figure 4-2**.

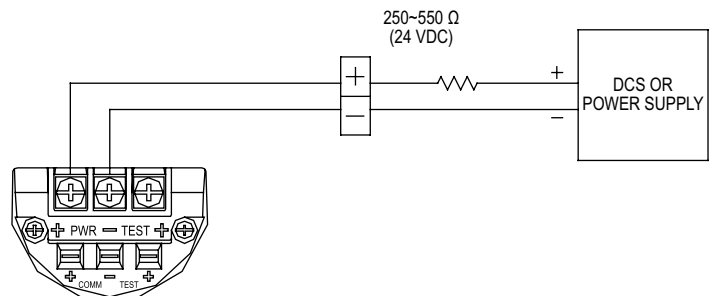

Figure 4-2: Wiring the 3200 pressure transmitter

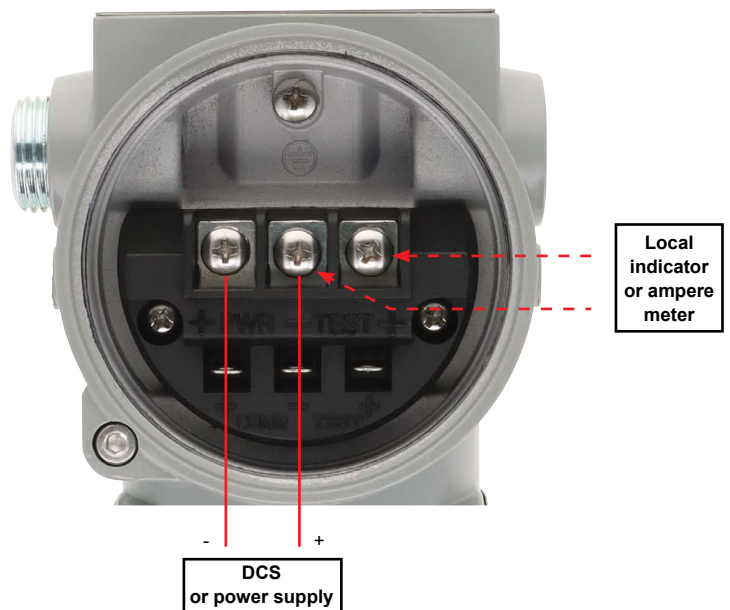

Figure 4-3: Picture of transmitter wiring terminal

4.7.4 Wiring

WARNING Explosion can result in death or serious injury:

- Do not remove the transmitter covers in an explosion-proof environment when the circuit is powered.
- Both transmitter covers must be fully engaged to meet explosion-proof requirements

A. Loop Configuration

Mercoid® 3200 Series Transmitters use a two-wire system for power, 4~20mA analog signal transmission and HART® digital transmission. A DC Power Supply is required for the transmitter loop. The transmitter and power supply should be connected as shown below.

1. Explosion-proof

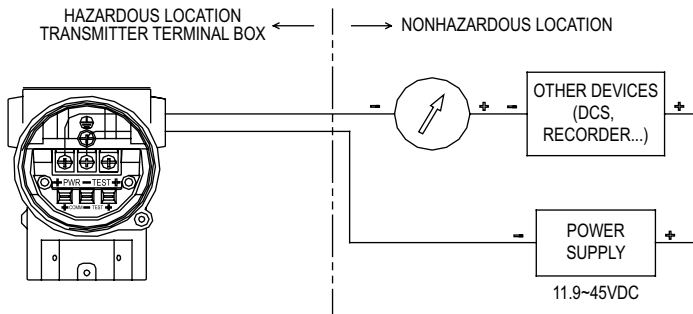

B. Wiring Installation

General-use (Figure 4-4a)

1. Use metallic conduit or waterproof cable glands for wiring.
 - a. Apply non-hardening sealant to the terminal box and the threads on the flexible metal conduit for waterproofing.

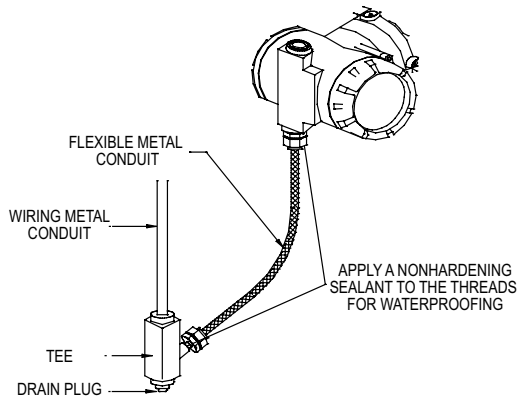

Figure 4-4a: Typical mounting using flexible metal conduit

Explosion-proof

1. Explosion-proof metal conduit wiring (Figure 4-4b)
 - a. A seal fitting must be installed near the terminal box port.
 - b. Apply a non-hardening sealant to the threads of the terminal connection box.

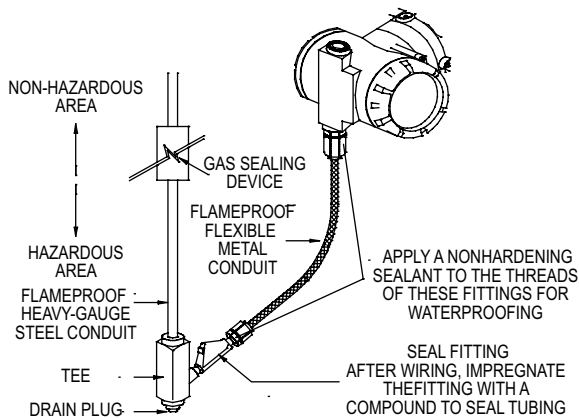
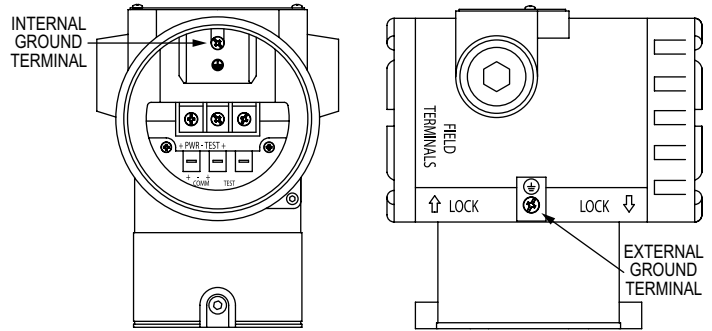

Figure 4-4b: Typical wiring using explosion-proof conduit

4.7.5 Grounding

- a. Grounding should satisfy KS requirements (grounding resistance should be 10 ohm or less). Grounding is required for explosion-proof applications and the ground resistance must be below 10 ohms.
- b. There are ground terminals on the inside and outside of the transmitter. Either of these terminals may be used
- c. Use 600V insulated PVC wire for grounding.



3200 Smart pressure transmitter
internal and external ground terminal

4.7.6 Power Supply Voltage and Load Resistance

When configuring the loop, make sure that the external load resistance is within the range (see figure below). The transmitter supply voltage should be:

- Standard: 11.9-45 VDC
- HART® Communication: 17.4-45 VDC

And maximum loop current is 24 mA, Load resistance R:
 $R = (E - 11.9) / 0.022$ (E = Power Supply Voltage)

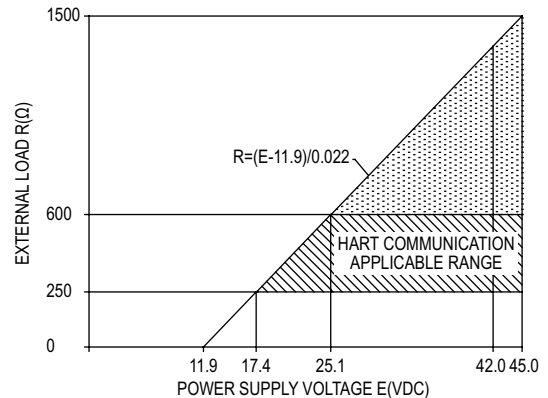

4.8 Mechanical Considerations

Figure 4-6 is a dimensional drawing for the 3200. Figure 4-7 shows how the A-630 angle bracket is mounted to a pipe.

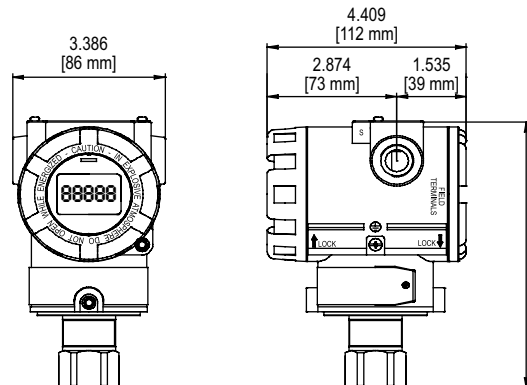

Figure 4-6: Model 3200 dimensional drawing

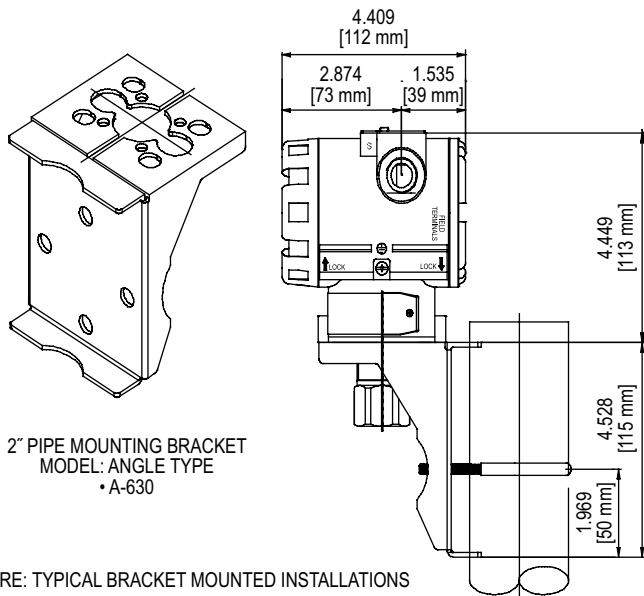

FIGURE: TYPICAL BRACKET MOUNTED INSTALLATIONS

Figure 4-7. A-630 mounting bracket

4.8.1 Mounting

Avoid installing transmitters in environments with excessive vibration. If it cannot be avoided, it is highly recommended to provide adequate support when mounting.

4.8.2 Consideration of Transmitter Access

When selecting the installation location, accessibility must be taken into consideration.

- Housing rotation: The housing can be rotated 90°.
- Wiring terminals: The cover and wiring terminals are easily accessible.
- LCD/Circuits: Install the transmitter in a location where it can be seen. For transmitters without an LCD, the cover and jumpers are easily accessible.

4.9 Environmental Considerations

4.9.1 Ambient Temperature

The transmitter ambient temperature range is 4 to 180°F (-20 to 60°C). If the ambient temperature is going to exceed the temperature range, precautions must be taken to keep the temperature within the temperature limits.

4.9.2 Toxic and Moist Environments

The 3200 housing will protect the transmitter against moisture or toxic material. The electronic circuit is separated from the terminals. The housing covers have o-rings that seal the housing, but moisture can penetrate the housing through the conduit. The transmitter should be mounted in a position to prevent moisture from entering the housing through the conduit.

4.9.3 Installation in Hazardous Location

The transmitter is designed with an explosion-proof housing. Installation environment must not exceed the explosion-proof rating.

Chapter 5 On-line Operation

5.1 Overview

This chapter describes how to configure the 3200 Smart Pressure Transmitter. The transmitter can be configured in On-Line or Off-Line mode. In On-Line Mode a compatible HHT or PC configuration device must be used.

5.2 Safety Messages

For added operator safety please pay specific attention to procedures outlined in this manual listed under the warning symbol (▲).

5.2.1 Warning

▲ WARNING Explosion can result in death or serious injury:

- Do not remove the transmitter covers in explosion-proof environments when the circuit is powered.
- Both transmitter covers must be fully engaged to meet explosion-proof requirements.

▲ WARNING Electrical shock can result in serious injury:

- When installing transmitters in close proximity of high voltage sources (near power lines) the transmitter leads can be subject to high voltages.
- Avoid contact with the leads and terminals.

5.2.2 Current to Passive Mode Configuration

For multi-drop mode the current output must be configured as passive mode. Please disregard any other messages shown on an HHT.

5.3 Configuration Data Review

Before operating the transmitter make sure the configuration data on the nameplate matches the application.

5.4 Configuration Verification

Before the transmitter is ready for service, the configuration must be checked to confirm the settings are configured for the application.

5.4.1 Process Variable

There are two process variables in the 3200 Smart Pressure Transmitter. The primary variable and temperature compensated SV (Second Variable), the PV value outputs the 4~20mA analog value.

5.5 Basic Setup

The correlation variable must be configured before operating the transmitter.

5.5.1 Select Sensor Range

The pressure range must be selected when ordering the pressure transmitter.

5.5.2 Set Output Units

Select from the following engineering units:

Unit: KPa, kg/cm², bar, psi, mmH₂O etc.

5.5.3 4-20 mA Configuration

Set the Zero and Span for the 4~20 mA analog output.

5.6 Detailed Setup

5.6.1 Set Fail Mode

When the sensor or microprocessor is not operating properly, the transmitter will output 3.75 mA or 21.75 mA based on the Fail Mode setting.

5.6.2 Set Dampening Time

The Dampening Seconds value changes the response time of the transmitter to smooth out variations caused by rapid process changes. Determine the appropriate dampening setting based on the required response time, signal stability, and other requirements of your system. The Dampening Seconds can be set from 0-60 seconds; the default dampening value is 1.0 second.

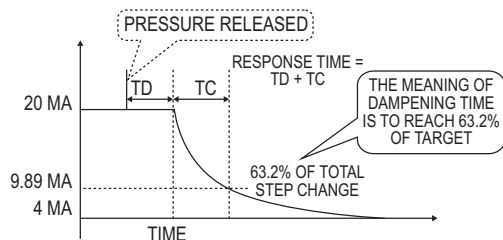

5.7 Configuration of Information Variable

5.7.1 Set Tag

Tags are an easy way to classify transmitters in multi transmitter application. Tags can use 8 words/numbers.

5.7.2 Set Messages

When using several transmitters, the user can define each transmitter by using 32 words/numbers. This message is saved in EEPROM.

5.8 Configuration of Breakdown Diagnostic Function

5.8.1 Loop Test

The Loop Test verifies the output of the transmitter, the integrity of the loop, and the operation of any recorders or similar devices installed in the loop. The following procedures are required for a loop test.

- Connect a reference meter to the transmitter.
- Select the Loop Test on the HHT and operate the Loop Test.
- Select current output (4mA/20mA/etc)
- If the readings match, then the transmitter and the loop are configured and functioning properly. If the readings do not match, then you may have the current meter attached to the wrong loop, there may be a fault in the wiring, the transmitter may require an output trim, or the current meter may be malfunctioning.

5.9 Calibration

The scale is implemented by calibrating the transmitter. Trim function has several calibration functions. Smart transmitters operate differently than analog transmitter. A smart transmitter uses a microprocessor that contains information about the sensor's specific characteristics in response to pressure and temperature for calculating the process variable. 4-20 mA configuration sets the transmitter's analog output to a selected upper and lower range and can be done with or without an applied pressure. 4-20 mA configuration does not change the factory characterization curve stored in the microprocessor. Sensor trimming requires an accurate pressure input and adds additional compensation to the factory characterization curve to optimize transmitter performance over a specific pressure range. 4-20 mA configuration provides the ability to readjust the 4~20 mA sensor inputs.

5.9.1 Sensor Trim

The Sensor trim function adjusts the A/D signal conversion within the transmitter sensor electronics and determines how it digitally interprets any pressure changes applied to the sensor inputs. It is highly recommended to perform a sensor trim when first commissioning the transmitter on site. There are three ways to trim the sensor: Sensor zero trim, full trim and zero adjustment. Sensor zero trim is a one-point adjustment typically used to compensate for the mounting position. Two point trim is a full sensor trim, in which two accurate pressures are applied (equal to or greater than the range values), and the output is linear. You should always adjust the low trim value first to establish the correct offset.

5.9.2 D/A (Digital to Analog) Trim

The D/A trim function makes minor adjustments to the analog (4-20 mA) output scaling from the transmitter. It is recommended to do a D/A trim on both hi (20 mA) & low (4 mA) values for best results. This function corrects any minuscule offsets within the D/A conversion of the transmitter

Chapter 6 Maintenance

6.1 Overview

This chapter describes diagnostic and maintenance.

6.2 Safety Messages

When the transmitter is in operation, operators should follow all safety messages. Potential safety issues are indicated by a warning symbol (▲). Refer to the following safety messages before performing any operation preceded by a (▲) symbol.

6.2.1 Warning

▲ WARNING Explosion can result in death or serious injury:

- Do not remove the transmitter covers in explosion-proof environments when the circuit is powered.
- Both transmitter covers must be fully engaged to meet explosion-proof requirements.

▲ WARNING Electrical shock can result in serious injury:

- When installing transmitters in close proximity of high voltage sources (near power lines) the transmitter leads can be subject to high voltages.
- Avoid contact with the leads and terminals.

▲ WARNING Electrical shock can result in death or serious injury:

- Only qualified personnel can configure and wire the 3200 Smart Pressure Transmitter.

6.3 Hardware Diagnostics

If there is a failure despite a diagnostic message on the HHT, **Table 6.1** can help troubleshoot the problem.

Symptom	Potential Source	Corrective Action
Transmitter does not Communicate with HART® Communicator	<ul style="list-style-type: none"> • Loop Wiring 	<ul style="list-style-type: none"> • Check for a 250-550 Ωs resistance between the power supply and HHT. • Check for adequate voltage to the transmitter (the transmitter requires 11.9 ~ 45 VDC). • Check for intermittent shorts, open circuits, and multiple grounds.
High Output	<ul style="list-style-type: none"> • Sensor Input Failure • Loop Wiring • Power Supply • Electronics Module 	<ul style="list-style-type: none"> • Connect HHT and enter the transmitter test mode to isolate a sensor failure. • Check for dirty or defective terminals, interconnecting pins, or receptacles. • Check the output voltage of the power supply at the transmitter terminals. It should be 11.9 to 45 VDC. • Connect HHT and enter the transmitter test mode to isolate module failure. Check the sensor limits to ensure the calibration adjustments are within the sensor range.
Erratic Output	<ul style="list-style-type: none"> • Loop Wiring • Electronics Module 	<ul style="list-style-type: none"> • Check the output voltage of the power supply at the transmitter terminals. It should be 11.9 to 45 VDC. • Check for intermittent shorts, open circuits, and multiple grounds. • Check for proper polarity at the signal terminals. • Connect HHT and enter the transmitter test mode to isolate an electronics mode failure.
Low Output or No Output	<ul style="list-style-type: none"> • Sensor Element • Loop Wiring • Electronics Module 	<ul style="list-style-type: none"> • Connect HHT and enter the transmitter test mode to isolate a sensor failure. • Is the PV out of range. • Check for adequate voltage to the transmitter (the transmitter requires 11.9 ~ 45 VDC). • Check for intermittent shorts, open circuits, and multiple grounds. • Check polarity of signal terminal • Check the loop impedance. • Connect HHT and check the sensor limits to ensure calibration adjustments are within the sensor range.

Table 6.1: Troubleshooting

6.4 Hardware Maintenance

The Mercoid® 3200 Smart Transmitter has no moving parts and requires little maintenance. If a transmitter fails, it must be returned to Dwyer Instruments, LLC for inspection, repair, or replacement.

6.4.1 Test Terminals

The test terminals are marked TEST on the terminal block. The test and negative terminals are connected to the power terminals; so long as the voltage across the receptacles are below the diode threshold voltage, no current will pass through the diode. To ensure that current isn't leaking through the diode, test the reading with an indicating meter. The test connection should not exceed 10 Ωs. A resistance value of 30 Ωs will cause an approximate 10 percent of reading error.

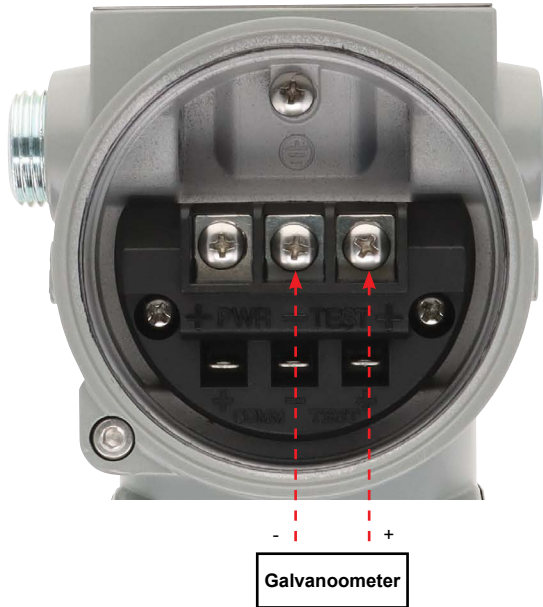

Figure 6-1: Test terminals

6.4.2 Disassembling the Housing

The transmitter is designed with dual-compartment housing; one contains the electronics module, and the other contains all wiring terminals and the communication terminals.



Figure 6-2: Structure of housing

6.4.2.2 Fail Mode Jumper Switch and EEPROM-Write

Fail-mode jumper switch and EEPROM-Write is located behind the front cover.

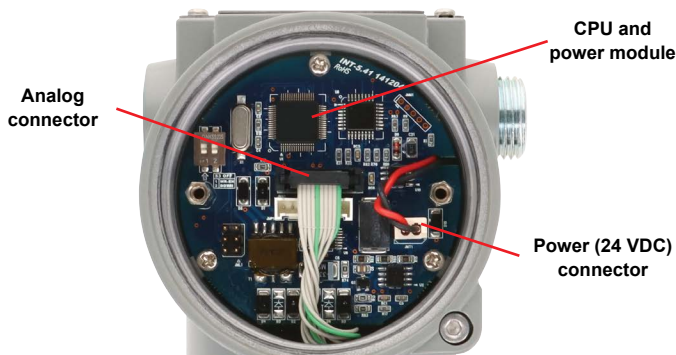

Figure 6-3: Structure of electronics module

Appendix I

3100 SMART PRESSURE TRANSMITTER - LCD DISPLAY CODE

Message	Description
ADJ-U	Zero adjustment value – used to configure transmitter when it is out of range (on higher side)
ADJ-L	Zero adjustment value – used to configure transmitter when it is out of range (on low side)
ZERO	Initial message when using Zero button
SPAN	Initial message when using Span button
BT-ERR	Button Sequence error
P-LOCK	Button input error - Protect Locked
ZT-ERR	Zero Trim value is over limit (10%)
-TR-	Zero Trim done
ZR-ERR	Setting Limit error when executing Zero button function
SP-ERR	Setting Limit error when executing Span button function
-ZR-	Zero button function done
-SP-	Span button function done
-ZA-	Zero Adjustment done
-DONE-	Configuration completed using buttons
RNGOVR	Limit error when executing other setting function
LCD_OV	Over Values for LCD
SCD-ER	Sensor Code Error
F-RST	Flash Setting Data Reset
F-LOCK	Flash Setting Data Reset, Protect Locked
F-FAIL	Flash Setting Data Reset Failure
-FR-	Flash Reset done
A-RST	Analog EEPROM Initializing Start
A-STOR	Analog EEPROM Stored
A-FAIL	Failure in writing configuration values on to the EEPROM of transmitter CPU
-AC-	Analog EEPROM Configuration done
S-FL	Sensor Fail
S-OP	Sensor Overpressure
AEP-RF	Check error with EEPROM on CPU board
TS-FL	Temperature Sensor Error
AEP-WF	Analog EEPROM write fail
EOSC	Crystal Element Defect Alarm
FAVE	Flash Access Violation

