

KTS100

Temperature Sensor



Description

KTS100 series wall mounted sensor is a low-cost temperature sensor specially designed for temperature measurement in HVAC field. It is suitable for building equipment automatic control system (BA system) of commercial buildings and other conventional buildings.

IP65 protection grade is convenient for outdoor measurement at the same time.

Features

- Range from -40 to +200°C
- Resistance output
- Standard accuracy, see table
- Protection class: IP65 / NEMA 4

Applications

KTS100 temperature transmitter used for temperature measurement in heating, ventilation and air conditioning systems enabling weather-dependent temperature regulation.



Technical Data

Model	KTS100
Temperature sensitive element	PT100 Class A Accuracy $\pm(0.15+0.002t)$
	PT 1000 Class A Accuracy $\pm(0.15+0.002t)$
	NTC 10k B3950 Accuracy B:3989K \pm 1%
	NTC 10k B3435 Accuracy B:3435K \pm 1%
	NTC 1k Accuracy B:3500K \pm 1%
	NTC 2k Accuracy B:3977K \pm 0.3%
Response time	<1min
Element connection	2-wire
Media	Air or liquid
Operating temp	-40 ... +70°C
Storage temp	-30 ... +70°C
Measuring range	-40 ... +200°C
Housing material	PC & ABS, UL94-V0
Protection	IP65/NEMA 4
Cable gland	M16*1.5

Notes On Disposal



Most Keram Controls products may contain valuable materials that should be recycled rather than treated as domestic waste. Please pay attention to the relevant regulations of local disposal.

Product Certification



Declaration of conformity
The declaration of conformity of the products can be found on our website [https://: www.keramcontrols.com](https://www.keramcontrols.com)

KTS100

Temperature Transmitter



≡ Dimensions (mm)

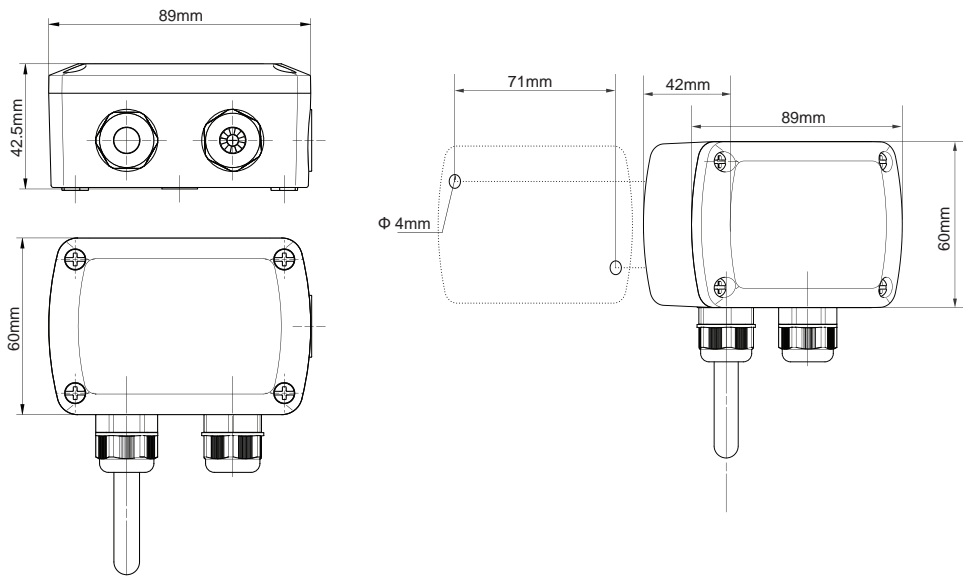

≡ Ordering Guide

KTS100		Element	
Model	Ranges	Element	
KTS100	PT100 Class A	(1)	
	PT1000 Class A	(2)	
	NTC 10k B3950	(3)	
	NTC 10k B3435	(4)	
	NTC 1k	(5)	
	NTC 2k	(6)	

≡ Order Examples

KTS100-1

Model	KTS100 Temperature Sensor
Element	PT100 Class A