



Model CMT200 Carbon Monoxide Transmitter

Specifications - Installation and Operating Instructions



CMT200

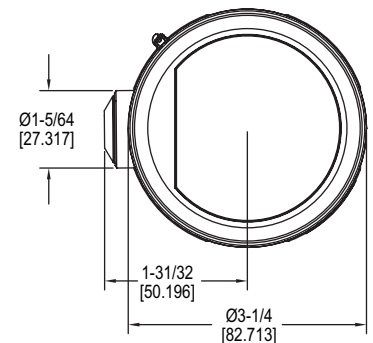
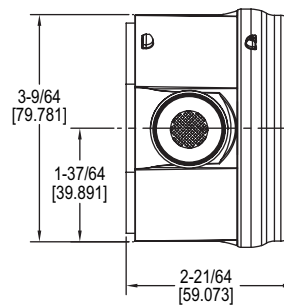

CMT200-R

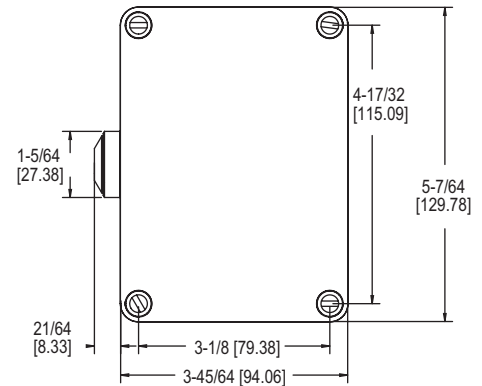
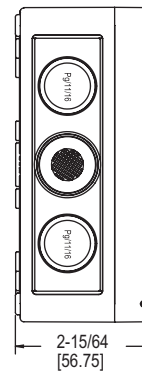

The **Model CMT200 Carbon Monoxide Transmitter** provides a field selectable current or voltage output that is proportional to the gas concentration in underground parking garages, vehicle maintenance facilities, or mechanical rooms. A field replaceable, electrochemical sensor provides accurate readings for up to 4 years with proper calibration. Field calibration can be done by using Model GCK-200CO-2000CO₂ calibration gas, Model A-507A calibration adapter, and the on board span and zero potentiometers.

WARNING Disconnect power supply before installation to prevent electrical shock and equipment damage. Make sure all connections are in accordance with the job wiring diagram and national and local electrical codes. Use copper conductors only.

CAUTION Use electrostatic discharge precautions (e.g., use of wrist straps) during installation and wiring to prevent equipment damage.

CAUTION Avoid locations where severe shock or vibration, excessive moisture or corrosive fumes are present.

CAUTION Do not exceed ratings of this device; permanent damage not covered by warranty may result. The 4 to 20 mA wiring configurations are not designed for AC voltage operation.

SPECIFICATIONS

Sensor: Field replaceable electrochemical, 4 year typical lifespan.

Range: 0 to 200 ppm.

Output Drift: <5% per year in air.

Coverage Area: 5000 to 7000 sq. ft. typical.

Accuracy: ±2% FS at the time of calibration.

Temperature Limits: -4 to 122°F (-20 to 50°C).

Storage Temperature: For best sensor life, 32 to 68°F (0 to 20°C).

Humidity Limits: 15 to 90% RH constant; 0 to 99% RH intermittent.

Response Time: <45 seconds to 90% of final value.

Calibration: 15 turn span and zero adjustment potentiometers.

Housing: UV resistant polycarbonate.

Output: Jumper selectable 4 to 20 mA (loop powered) or 2 to 10 V (load must be >50 KΩ).

Power Requirements: Current Output: 18 to 28 VDC; Voltage Output: 18 to 28 VDC/VAC, reverse polarity protected.

Electrical Connection: Removable terminal block, add two PG11 and one PG 16 knockouts for conduit fitting.

Weight: 0.28 lb (0.11 kg).

Agency Approvals: CE.

WIRING

Use maximum 18 AWG wire for wiring terminals. Refer to Figure 1 or Figure 2 for wiring information. The terminal block is removable for ease of installation.

4 to 20 mA Output

Before wiring for 4 to 20 mA output, check that the jumper P1 is connected so that the jumper is on the two pins furthest from the terminal block as shown in figure 1. 4 to 20 mA output may be powered by 18 to 28 VDC. The transmitter is reverse polarity protected. The load must not exceed the maximum loop resistance, R_{max} , listed on the next page. The load and power supply should be connected according to Figure 1.

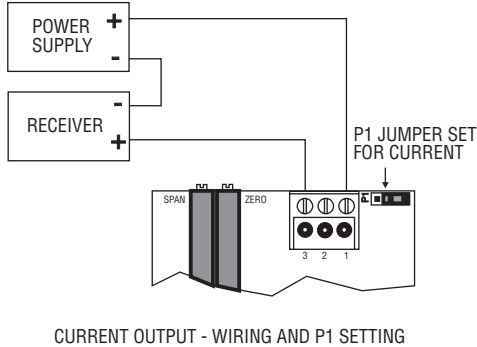

Figure 1

Max Loop Resistance For 4 to 20 mA Outputs

The maximum allowable loop resistance depends on the power supply voltage. Maximum loop voltage drop must not reduce the transmitter voltage below the 18 VDC minimum. Maximum loop resistance can be calculated with the following equation. V_{ps} is the power supply voltage.

$$R_{max} = \frac{V_{ps} - 18}{20 \text{ mA}}$$

Some receivers, particularly loop powered indicators, may maintain a fixed loop voltage to power the device. This voltage drop must also be subtracted from the power supply voltage when calculating the voltage margin for the transmitter. The following equation takes this into account. V_{rec} is the receiver fixed voltage.

$$R_{max} = \frac{V_{ps} - 18 - V_{rec}}{20 \text{ mA}}$$

2 to 10 VDC Output

Before wiring for 2 to 10 VDC output, check that the jumper P1 is connected so that the jumper is on the two pins closest to the terminal block as shown in figure 2. 2 to 10 VDC output may be powered by 18 to 28 VAC or VDC. The transmitter is reverse polarity protected. The load must be greater than 50 K Ω . The load and power supply should be connected according to Figure 2.

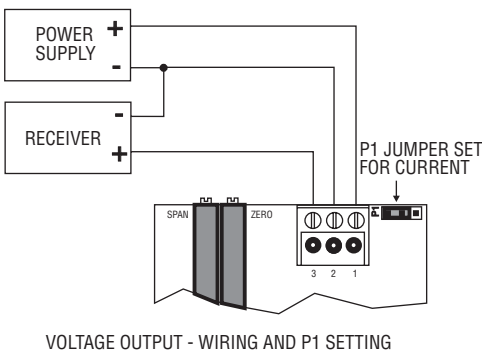

Figure 2

NOTICE

The electrochemical sensors should be stored in an environment with a minimum humidity level of 20% RH. If the sensor dries out, replacements will not be covered under warranty, but they can be revived by allowing them to stabilize in an environment above 40% RH for 10 days. Once revived, they need to be recalibrated before use.

INSTALLATION

NOTICE

These are general guidelines. Local laws or ordinances will take precedence.

- The transmitter should be mounted at normal breathing height, approximately 5 to 6 ft above the floor.
- The unit may be mounted in the horizontal or vertical position. It should be mounted in an area that is shielded from direct contact with the elements or direct sunlight.
- Mount in an area that will prevent the sensor from having any direct contact with water.
- The unit should be placed in an area that will give an average of the air quality. Do not place the unit so it will receive direct engine exhaust. Prolonged exposure to direct engine exhaust may damage the sensor.

MOUNTING

1. Twist the lid a quarter turn and pull the lid from the base housing.
2. Remove the desired conduit fitting knock out and install conduit fitting (not provided).
3. Position the transmitter where it is to be mounted and mark the mounting hole located in the center of the housing base.
4. Drill or punch out marked locations.
5. Place the transmitter on the wall and align the mounting hole. Install the transmitter using the included screw and washer through the mounting hole.
6. Set the jumper selection for current or voltage output.
7. Proceed with the wiring according to diagrams in figures 1 and 2.
8. Replace the cover.

CALIBRATION

Calibration of the Model CMT200 requires an A-507A calibration adapter, model GCK-200CO-2000CO₂ calibration gas, a multimeter, and a small flat head screw driver.

1. Turn off power to the transmitter.
2. Remove the lid from the housing by twisting it a quarter turn and pulling off.
3. Replace the receiver shown in figure 1 or 2 with a multimeter and restore the power to the transmitter.
4. Attach the tubing from the zero calibration gas to the A-507A calibration adapter.
5. Securely attach the A-507A to the CMT200 as shown in figure 3.
6. Allow the calibration gas to flow at a rate of 0.5 to 1.0 slpm for at least 3 minutes.
7. Adjust the zero potentiometer (blue) until the output reading on the multimeter reads 4 mA or 2VDC (depending on output selection).
8. Repeat steps 4 through 6 using the span calibration gas.
9. Adjust the span potentiometer (grey) until the output reading on the multimeter reads 20 mA or 10 VDC (depending on output selection).
10. Turn off the power to the transmitter.
11. Replace the multimeter with the receiver as shown in figures 1 and 2 and restore the power to the transmitter.
12. Remove the A-507A calibration adapter.
13. Replace the lid on to the transmitter.

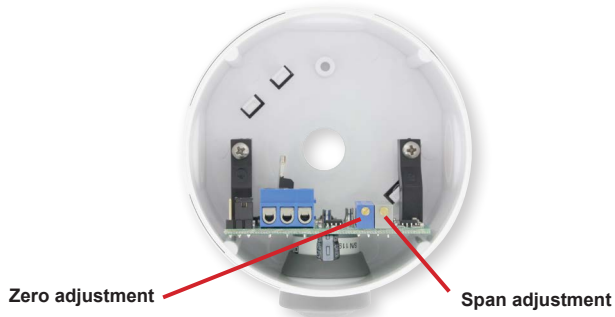

CMT200

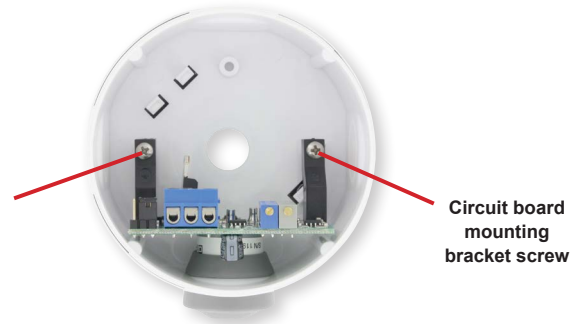

CMT200

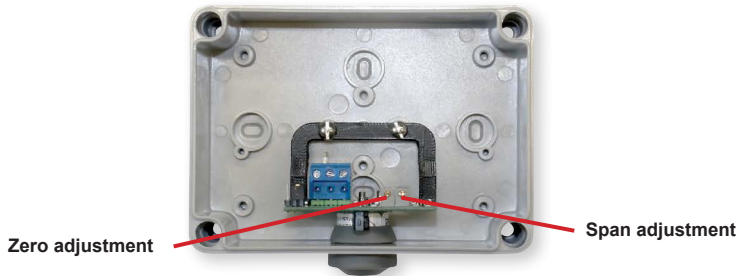

CMT200-R

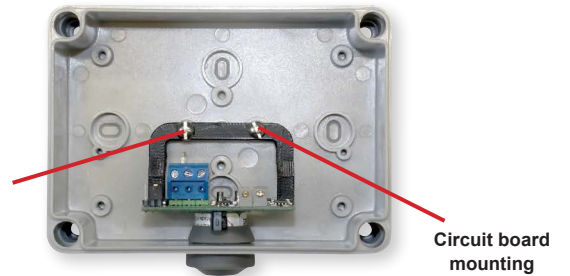

CMT200-R

Figure 3

Figure 4

NOTICE

If the span potentiometer on the Model CMT200 cannot restore the output to 20 mA, the sensor will need to be replaced.

Sensor Replacement

A replacement sensor is available from Dwyer Instruments, Inc. Order part number A-505 for a replacement CO sensor.

1. Turn off power to the transmitter and remove the terminal block from the circuit board.
2. Remove the two screws in the circuit board mounting bracket shown in Figure 4.
3. Gently slide the circuit board and sensor out of the sensor guard.
4. Remove sensor by gently pulling the sensor straight out of its sockets.
5. Install the new sensor by gently pressing the pins of the sensor into the sockets in the circuit board.
6. Slide the sensor and circuit board back into the sensor guard and align the mounting holes on the circuit board brackets with the holes on the housing.
7. Reattach the circuit board bracket to the housing and the terminal block to the circuit board.
8. Go through the calibration procedures in the calibration section.

NOTICE

When replacing the sensor, reset each potentiometer position to the middle of the range before adjusting the calibration.

MAINTENANCE/REPAIR

Upon final installation of the Model CMT200 Transmitter, no routine maintenance is required with the exception of calibration. As with all electrochemical type gas sensors, routine calibration is required. It is recommended that units be re-calibrated at 6 month intervals, to maintain the published accuracy, or as required by local ordinances or other requirements. The units will maintain 5% accuracy if they are re-calibrated at 12 month intervals.



This symbol indicates waste electrical products should not be disposed of with household waste. Please recycle where facilities exist. Check with your Local Authority or retailer for recycling advice.

Except for sensor replacement and calibration, the Model CMT200 is not field serviceable and should be returned if repair is needed (field repair should not be attempted and may void warranty). Be sure to include a brief description of the problem plus any relevant application notes. Contact customer service to receive a return goods authorization number before shipping.

